

SUBMERSIBLE PUMPS

RV - HEAVY DUTY SLURRY PUMPS



WEDA PUMP

RV - Slurry Pumps

Heavy Duty

The RV range of totally submersible pumps has been designed for the most difficult pumping applications where traditional drainage pumps are not enough.

Features

Unique concept

The combination of thoroughly-tested slurry pump wear parts and purpose-built fully submersible electric motor makes the RV heavy duty slurry pump concept unique in its class.

Low pressure seal

The mechanical shaft sealing is never exposed to the pump pressure, since the connection between the motor and the pump casing is open. Leakage from the pump casing is controlled by efficient sealing-vanes on the back of the impeller.

Leakage monitor

The oil-chamber between the seals provides a buffer against the surrounding medium, and it is fitted with a leakage monitor to warn against water penetration. The motor is also fitted with temperature monitors and a leakage probe for the stator housing.

Simple monitoring

The temperature and leakage monitors can be connected to a simple control-box or to an existing monitoring system.

Wear parts

The heavy built pump components are identical to those used in the Vertical slurry pumps, and are designed for highly abrasive tasks. The wear parts are stocked in SHR, which is a high-chrome/nickel alloy casting, with a hardness in excess of 550 HB, or coated in natural rubber or polyurethane. Other options are available for special applications.

Motor size

The pump size and motor specification can be selected to suit the job. The minimum information required for proper selection is:

- Capacity
- Fluid density and description of any contaminants
- Total discharge head, or a description of the pipe system.

Design Features

Motor: class F (155°F).

Bearings: heavy duty, greased for life.

Shaft: Stainless steel.

Oil housing: with flexible rubber bellows.

Shaft Sealing: two independent mechanical seals, running in biologically degradable oil.

At the pump side tungsten carbide, at the motor side carbon on ceramic.

Expeller disc: Assembled on the pump shaft behind the impeller to protect the outer seal.

Bolts & Nuts: Stainless steel.

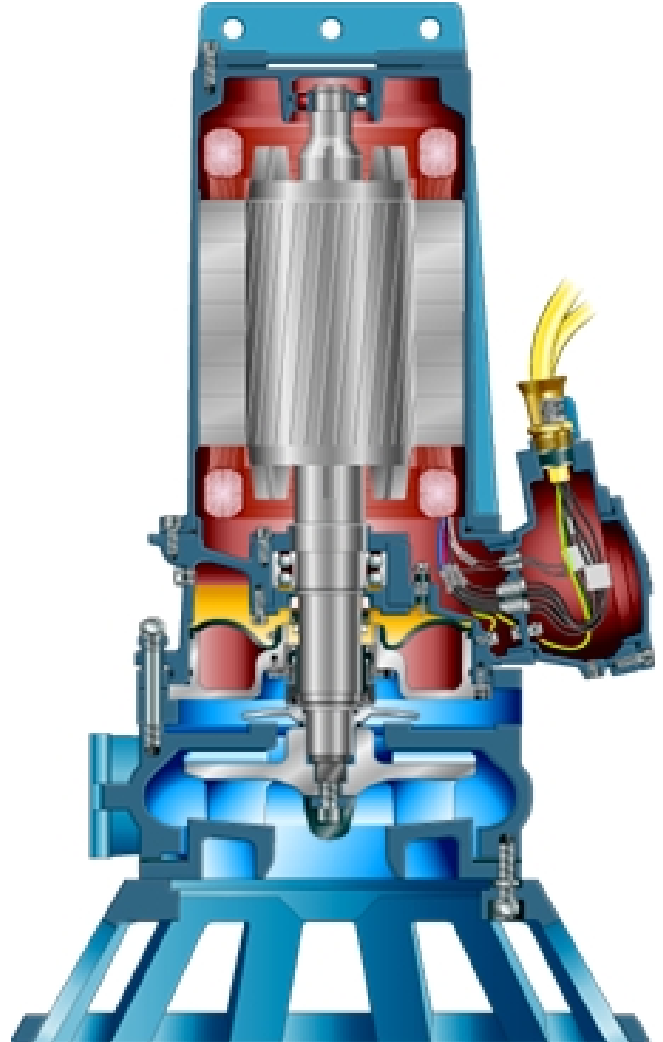

Options

Flameproof motors: certified to European standards EN 50014/18/19 (BS 5501), class EEx de IIB T3 or T4, and to American FMRC standard, class 1, division 1, groups C&D T4.

Cooling jacket: for continuous dry running at full load. (External water supply required).

Discharge bend: Wear resistance rubber lined bend.

Suction strainer:

to prevent oversize particles from clogging of the impeller.

Spray ramp: for sand dredging.

Voltages: Motors are available for 400V 50Hz and 440V 60Hz. Other voltages upon request.

Characteristics

RV40 series

1450 min⁻¹

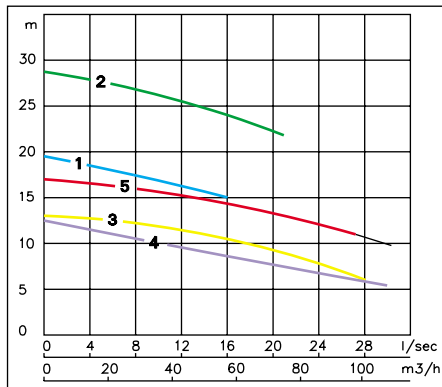

N° Model	Discharge [mm]	Suction [mm]	Power [kW]	A [mm]	B [mm]
1 RV4020	50	65	6-12	376	896
2 RV4021	50	65	7.5-12	376	932
3 RV4030	80	100	6-12	664	997
4 RV4031	80	100	6-12	664	997
5 RV4032	80	100	7.5-12	664	997

960 min⁻¹

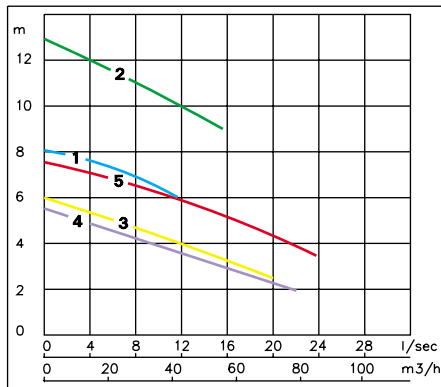

N° Model	Discharge [mm]	Suction [mm]	Power [kW]	A [mm]	B [mm]
1 RV4020	50	65	4	376	896
2 RV4021	50	65	4	376	932
3 RV4030	80	100	4	664	997
4 RV4031	80	100	4	664	997
5 RV4032	80	100	4	664	997

RV60 series

1450 min⁻¹

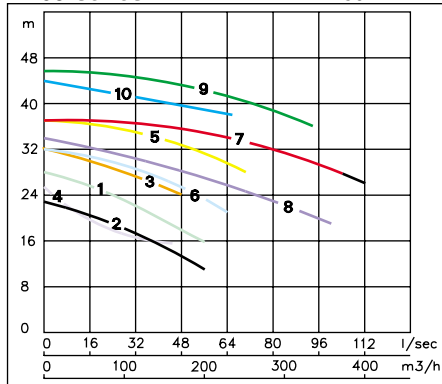

N° Model	Discharge [mm]	Suction [mm]	Power [kW]	A [mm]	B [mm]
1 RV6040	100	125	16-48	740	1197
2 RV6041	100	125	16-48	740	1197
3 RV6042	100	125	16-48	740	1197
4 RV6043	100	125	16-48	740	1197
5 RV6044	100	125	22-48	740	1197
6 RV6045	100	125	22-48	740	1197
7 RV6060	150	165	48	824	1262
8 RV6061	150	165	48	824	1262
9 RV6062	150	165	48	824	1262
10 RV6063	150	165	48	824	1262

960 min⁻¹

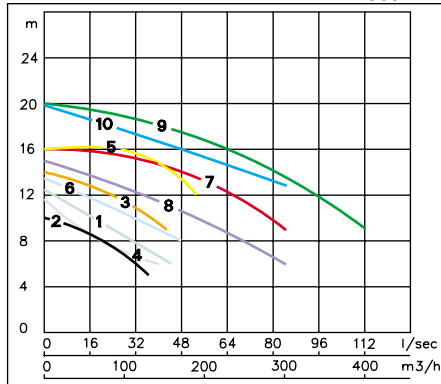

N° Model	Discharge [mm]	Suction [mm]	Power [kW]	A [mm]	B [mm]
1 RV6040	100	125	9-26	740	1197
2 RV6041	100	125	9-26	740	1197
3 RV6042	100	125	9-26	740	1197
4 RV6043	100	125	9-26	740	1197
5 RV6044	100	125	9-26	740	1197
6 RV6045	100	125	9-26	740	1197
7 RV6060	150	165	20-26	824	1262
8 RV6061	150	165	20-26	824	1262
9 RV6062	150	165	20-26	824	1262
10 RV6063	150	165	20-26	824	1262

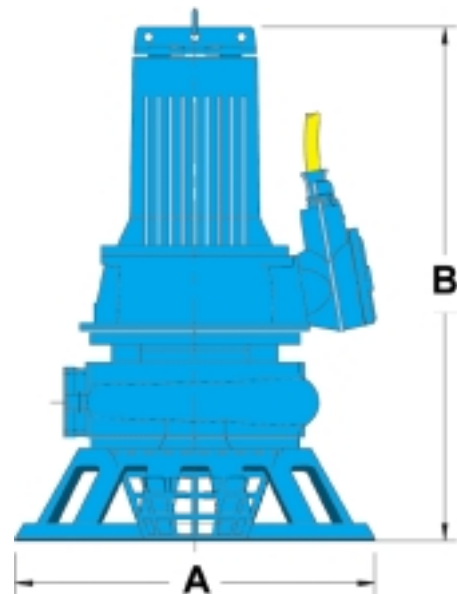

RV80 series

1450 min⁻¹

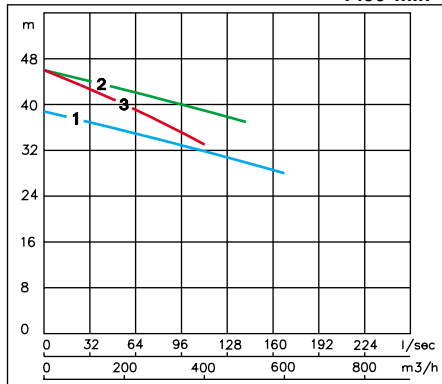

N° Model	Discharge [mm]	Suction [mm]	Power [kW]	A [mm]	B [mm]
1 RV8060	150	165	60-100	824	1487
2 RV8061	150	165	60-100	824	1487
3 RV8062	150	165	60-100	824	1487

960 min⁻¹

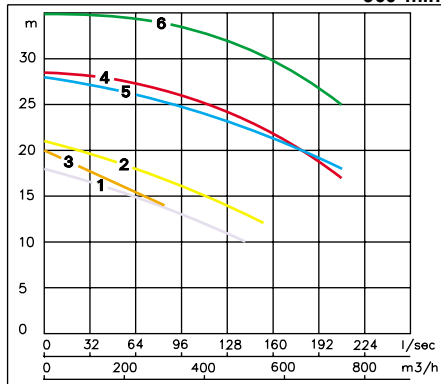

N° Model	Discharge [mm]	Suction [mm]	Power [kW]	A [mm]	B [mm]
1 RV8060	150	165	45-60	824	1487
2 RV8061	150	165	45-60	824	1487
3 RV8062	150	165	45-60	824	1487
4 RV8080	200	250	45-60	1020	1590
5 RV8081	200	250	45-60	1020	1590
6 RV8082	200	250	45-60	1020	1590

750 min⁻¹

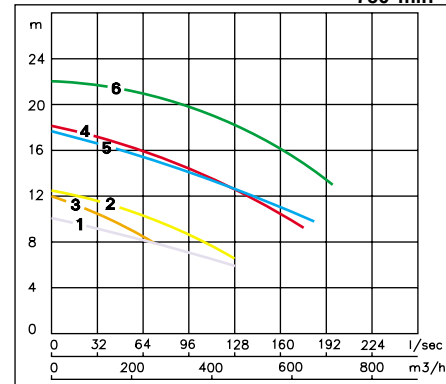

N° Model	Discharge [mm]	Suction [mm]	Power [kW]	A [mm]	B [mm]
1 RV8060	150	165	26-50	824	1487
2 RV8061	150	165	26-50	824	1487
3 RV8062	150	165	26-50	824	1487
4 RV8080	200	250	26-50	1020	1590
5 RV8081	200	250	26-50	1020	1590
6 RV8082	200	250	26-50	1020	1590

Options available

	Impeller type			Wear part materials	
	Semi-open	Closed	Vortex	Metal	Elastomers
RV4020	●			●	●
RV4021	●			●	●
RV4030		●		●	●
RV4031	●			●	●
RV4032	●			●	
RV6040		●		●	●
RV6041	●			●	●
RV6042		●			●
RV6043			●	●	
RV6044		●		●	
RV6045	●			●	●
RV6060		●		●	●
RV6061	●			●	●
RV6062		●		●	●
RV6063	●			●	
RV8060			●	●	
RV8061			●	●	
RV8062	●			●	
RV8080		●		●	●
RV8081	●			●	●
RV8082		●		●	

The RV pumps are supplied in three basic models, Type 1, 2 & 3.

Type 1

Semi-open impeller and pump casing with spray holes. Part of the pressurized liquid is directed towards the bottom of the sump. This not only agitates solids in the sump but also de-aerates the pump to prevent air-blocking.

Type 2

Closed impeller and casing without sprayholes for maximum performance and high heads.

Type 3

Vortex impeller for non-clog pumping of fibrous and coarse solids. Can be equipped with casing with or without spray holes

Impeller types

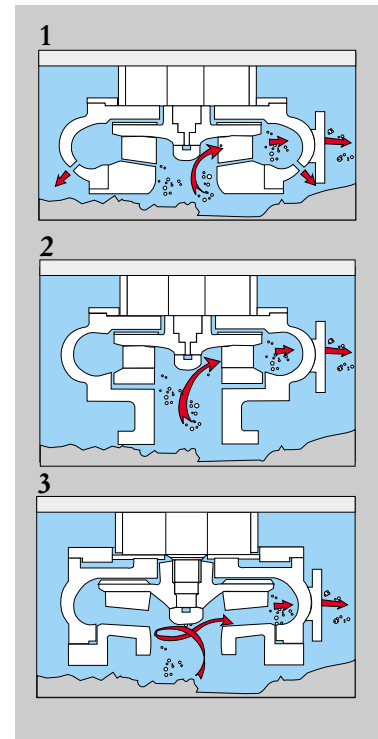

Typical applications

The pumps are designed for pumping abrasive suspensions such as pulp, slurries, mill scale, industrial effluents and drainage from mine galleries and tunnels.

The pumps are commonly used in sand dredging and floor cleaning applications.

Customers for RV heavy duty slurry system include the mining industry, steelworks and the construction industry, but it can be used wherever there is a need to pump abrasive suspensions.

Continuous operation is recommended, especially when pumping coarse and fast settling solid particles.

Installation options

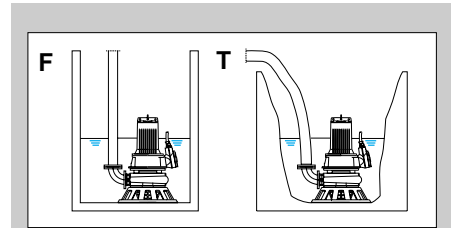

All pumps are delivered for semi permanent free-standing "F", with stand and discharge bend or suspended. "T" intended for connection of flexible material handling house.



WEDA PUMP

Delta Pompen B.V. Rigaweg 17 9723 TE Oldenzaal The Netherlands, Tel.: +31(0)50-2072380

<http://www.wedapump.com> - info@deltapompen.com