

WEDA PUMP

World leader in professional submersible drainage pumps

INSTRUCTIONS & SPAREPARTS CATALOGUE RL 4150



RL4150 – IS – 10591 – 1 – ENG – GSNL

SAFETY INSTRUCTIONS

- **MACHINES SUBMITTED** : Powered with : Electric, Pneumatic, Petrol or Diesel engine.

- **SYMBOLS** : The words **WARNING** and **CAUTION** used in safety instructions, have the following meanings :
WARNING indicates hazards or hazardous procedures which could result in serious injury or death , if the **WARNING** is not observed.
CAUTION indicates hazards or hazardous procedures which could result in injury or damage to equipment if the **WARNING** is not observed.

- **IMPORTANT RULES FOR YOUR SAFETY** :



WARNING

The machine must not be modified without prior consent of the manufacturer. Use only original parts. If modifications are made without prior consent of the manufacturer there is a risk of serious injury to the personal.

- These safety recommendations have been compiled from international safety standards. Local regulations must also be checked and observed. Before using the machine, read carefully these instructions and keep them in a safe place.
- Make sure that the signs about using, safety, and maintenance are always legible.
- The use of the machine is restricted to the applications specified in the product literature.
- Always change damaged parts immediately. Change wear parts in due time.

- **SAFETY EQUIPMENT** :



WARNING

The admissible sound level of 85 dB (A), can be exceeded because of the machine and/or the application. Long time exposure to loud noise without ear protectors can cause permanent damage to hearing. Long time exposure to vibrations can damage the hands, fingers and wrists. Do not use the machine if you are experiencing discomfort, cramp or pain. Consult a doctor before working again with the machine.

- Always use approved safety equipment. The following safety equipment applies to operators and other personnel in the immediate vicinity of the working zone.
- Safety helmet.
- Ear protectors.
- Dust mask in dusty environments.
- Protective gloves.
- Protective shoes.
- Goggles.

To avoid the risk of clothes being caught in the machine, avoid wearing loose-lifting clothes. If you have long hair, cover it with a hair net.

- **WORKING AREA** :



WARNING

Do not use the machine in explosive environments. Do not operate a machine powered by a petrol or diesel engine in poorly ventilated spaces. These types of engines produce toxic gases which can cause serious health troubles.

- POWER SUPPLY :



WARNING

Make sure that the power supply equipment complies with the relevant safety requirements of the local and the international standards.

- **Electric machine** : It must be ensured that the machine is connected to the voltage and the frequency specified on the name plate. The power supply cable has to be properly sized. Check that the cable and the plug of the machine are not damaged. Never switch off the machine by pulling the plug from its socket. Use the machine switch. Keep the cable out of the moving parts of the machine.

- **Pneumatic machine** : Check that the compressed-air hose and the hose coupling are not damaged. Never attempt to loosen a compressed-air hose which is pressurized. First switch off the air at the compressor and then leave the machine running itself to discharge the hose after some seconds.

- **Machine powered by petrol or diesel engine** : Petrol has an extremely low flash-point and can be explosive in certain situations. Keep away from all hot or spark-generating objects, do not smoke, when handling fuel. Wait until the machine has cooled before filling the tank. Avoid spilling petrol or diesel on the ground.

- STARTING THE MACHINE :



CAUTION

Before starting make yourself familiar with the machine and make sure that the machine does not show any obvious faults. Then start the machine according the instruction and spare parts catalogue.

- OPERATION :



CAUTION

Use the machine only for the purpose for which it is intended. Make sure you know how to stop the machine quickly in the event of an emergency situation. Do not touch rotating parts during operation.

- MAINTENANCE :



CAUTION

Maintenance work must only be carried out by skilled personnel. Keep unauthorized persons away from the machine. Do not carry out maintenance work while the machine is moving or the engine is running. Never use a machine which is damaged.

- BE ALERT :



CAUTION

Always concentrate on what you are doing. Use common sense. Never operate the machine if you are tired or under the influence of drugs alcohol or other substances which can affect your vision, reaction, ability or judgement.

GENERAL

The RL submersible drainage pumps are designed for pumping lightly contaminated water .

DESIGN

The heavy duty light weight aluminium construction includes a cooling jacket ensuring adequate motor cooling at all times .

The pumps are in 'plug and pumping design' , with built-in full overheat motor protection .

The versions with level float switch allow automatic operation .

The unique cartridge type seal package can be easily replaced on site with only minimum downtime .

For demanding applications as in construction works and mining , the impellers are made for wear resistant Hi-Chrome iron and all other components are rubber lined .

The impeller clearance is easily adjustable to compensate for wear .

TECHNICAL DATA

Pump :	RL4150
Discharge mm - (in)	76 - (3") 102 - (4")
Suitable for media with pH	5 - 8
Maximum water temperature	40°C
Maximum submersible depth m - (ft)	20 - (67)
Maximum solids size mm - (in)	Ø6 - (0.24)
Weight (excluding cable) kg - (lb)	55 - (121)
Strainer	Rectangular holes 6 x 32.5 mm
Speed rpm 50Hz (60Hz)	2850 - (3420)
Stator insulation class	F (155°C)

Voltages V	Phases	Frequency Hz	Rated current A			Rated electrical power (kW)		
			LH	MH	HH	LH	MH	HH
400	3	50	10.2	10.6	13.4	5.1	5.3	7.7
415	3	50	10.2	10.6	13.4	5.1	5.3	7.7
440-460	3	60	9.2	9.5	12	5.9	6.1	8.9

Other voltages upon request

IMPORTANT

The above information is a general description only, is not guaranteed and contains no warranties of any kind

Power cables (50Hz)

20 meters 4x2.5 mm² for 400-415V.
All cables polychloroprene type HO7RN-F .

Power cables (60Hz) only for CSA approved types .

20 meters SOW 4xAWG14 for 440-460V

Hydraulic characteristics

60Hz

50Hz

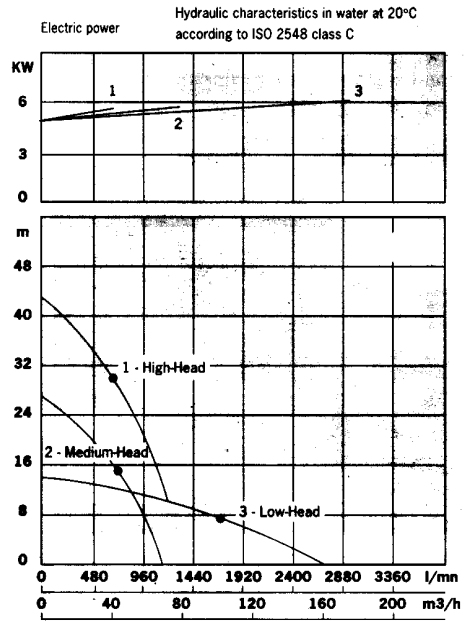
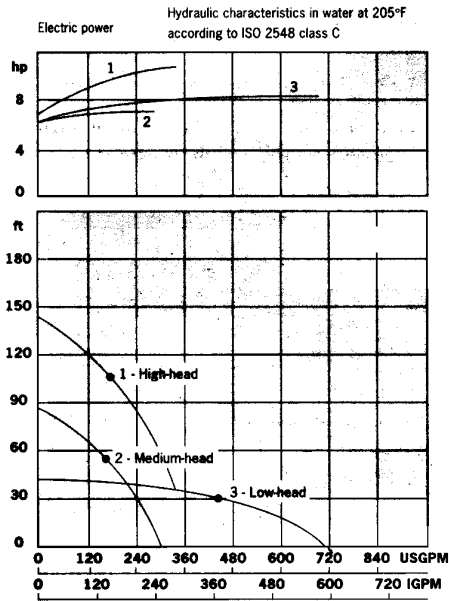

Dimensions

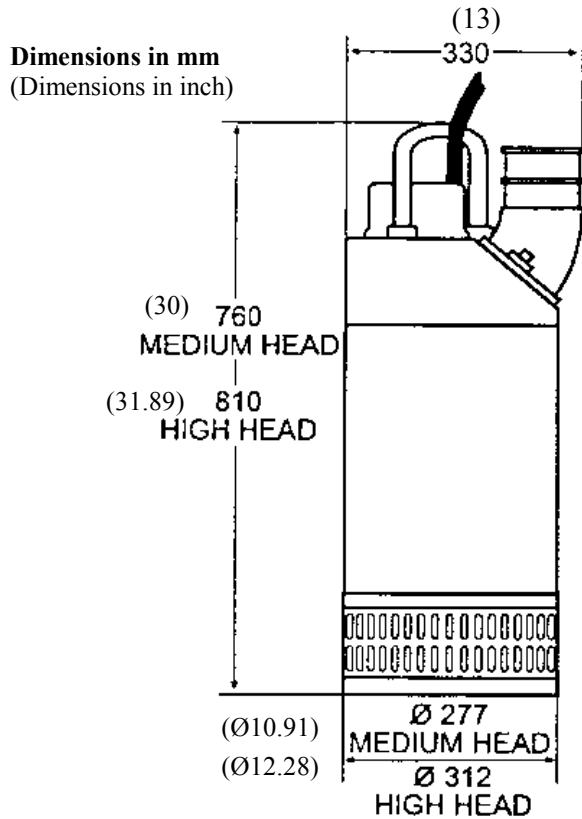

DISCHARGES AVAILABLE

3" Hose standard P/N W203562 with 2 clamps
3" BSP - thread P/N W203484
3" NPT - thread P/N W203570
4" Hose standard P/N W203564 with 2 clamps
4" BSP - thread P/N W203482
4" NPT - thread P/N W203572

Note :the discharges have to be ordered separately .

PUMPS PART NUMBERS

<u>Power supply</u>	<u>Part Number (1)</u>
400V-3-50Hz Low head	RL4152B3562
400V-3-50Hz Medium head	RL4154B3562
400V-3-50Hz High head	RL4156B3562
415V-3-50Hz Low head	RL4152B3572
415V-3-50Hz Medium head	RL4154B3572
415V-3-50Hz High head	RL4156B3572
440-460V-3-60Hz Low head	RL4153B3562
440-460V-3-60Hz Medium head	RL4155B3562
440-460V-3-60Hz High head	RL4157B3562

(1) The letter B means. basic construction, but the following main options are also available , according to the pump type :

C : High style strainer , stainless steel .
H : Canada Standard Association certified.
N : Level control NVB system.
Z : Zinc anodes.
P : N + Z options.

Be sure that the stator voltage coincides with the contactor voltage .

Here is the combinations for the most common pumps . In case of special applications please contact us .

INTALLATION



The pump must not be used in an explosive / inflammable environment or used to pump inflammable liquids !

- Route the cables so that connectors do not lie in the water. Consider the risk of electrical accident.



Never lift the pump by its power cable !

- Connect a discharge hose of approved pressure class.
- The discharge hose may be thrown off when the pump starts.
- No one must be allowed in the water, e.g. swimming pools, when the pump is running.
- Check that the pump is standing steady, or suspend it from its lifting ring.
- **Check the direction of rotation, pointed by the starting kick arrow printed in the outer casing (anti-clockwise)**
The pump will start instantaneously when it is connected to the power supply.
The pump may kick violently when it starts.
In case of wrong direction of rotation two phases should be inverted from the supply (three phases voltage only).



ELECTRICAL CONNECTION

Check that the details on the pump data plate match with the mains voltage and frequency.



**The electrical installation must be carried out by a qualified electrician !
Local installation regulations must be followed !**

Make sure that the pump is properly earthed. The earth conductor must be slightly longer than the phase conductors. If the motor power cable is accidentally pulled off, the earth conductor must be the last conductor to be removed from the terminals.

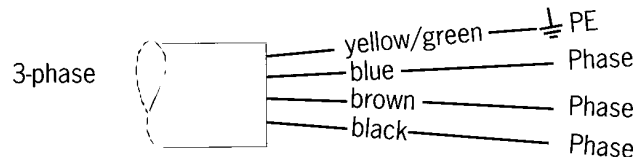

Pumps must be connected to an approved motor protection.

BUILT-IN MOTOR PROTECTION



Check that the pump is disconnected from the power supply before starting any work !

The pump's built-in motor protection switches off the contactor automatically if the motor overheats. Then, the fault must be identified and corrected. After cooling to normal working temperature, the motor protection switches on the contactor and the pump starts again.

TROUBLE SHOOTING

Fault location	Cause	Action
Pump will not start.	<ol style="list-style-type: none"> 1. Fuses blown 2. Broken cable 3. Power failure 4. Jammed impeller 5. Faulty contactor 6. Stator winding burnt-out 7. Incorrect phase sequence (3 phases) 	<ol style="list-style-type: none"> 1. Replace fuses 2. Service 3. – 4. Clean bottom of pump 5. Service 6. Service 7. Change 2 phases in plug
Pump starts, but stops again.	<ol style="list-style-type: none"> 1. Pump runs backwards (3 phases) 2. Pump connected to wrong voltage 3. Phase interruption 4. Strainer blocked 5. Insufficient water level 6. Voltage too low when using an extra cable 7. Water too hot 	<ol style="list-style-type: none"> 1. Change 2 phases in plug 2. Select the right voltage 3. Check fuses 4. Clean strainer 5. Stop the pump 6. Increase the extra cable section 7. Switch off power
Pump works, but delivers too small water volume .	<ol style="list-style-type: none"> 1. Impeller worn 2. Pump runs backwards (3 phases) 3. Hose dimensions unsuitable 4. Insufficient discharge head 	<ol style="list-style-type: none"> 1. Adjust pump/replace impeller 2. Change 2 phases in plug 3. Change to suitable hose 4. Select a bigger pump

MAINTENANCE

RL4150 : Every six months, check the level and quality of the oil in conjunction with servicing. If the oil is emulsified with water, the seal package must be removed from the rotor shaft for replacement. (See Fig. 2).

<u>Company</u>	<u>Oil</u>
Statoil	Hydra Way HM32
Texaco	Rando Oil HD32
Mobil	DTE24
Castrol	Hyspin AWS32
Shell	Tellus Oil32

Quantity : 1,4 L

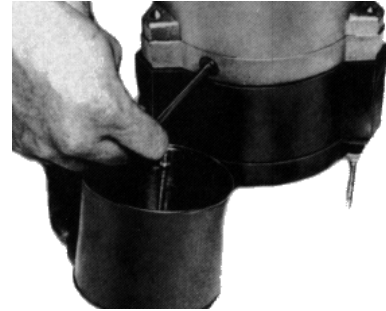

Fig. 2

Pump performance

To keep the pump performance, the gaps must be as small as possible. The gap between the impeller and the wear plate is adjustable with trim washers. The gap between the impeller and the diffuser is adjusted by alternatively tightening the nuts fixing the diffuser. After adjustment the impeller must be capable of rotation by hand.



Worn impellers can have very sharp edges. Wear safety gloves !



Fig.4

MAINTENANCE KITS

Part number	Description	Parts included
W254495	Gasket set	Parts 7,11,27,28,36,40,42,53,57,61,64,74,82,94 .
W743601	Wear part set RL4152 - 50Hz - Low pressure	Parts 34,48,69,75,77,80 .
W743602	Wear part set RL4153 - 60Hz - Low pressure	Parts 34,48,69,75,77,80 .
W743603	Wear part set RL4154 - 50Hz - Medium pressure	Parts 34,48,70,76,77,80 .
W743604	Wear part set RL4155 - 60Hz - Medium pressure	Parts 34,48,70,76,77,80 .
W743605	Wear part set RL4156 - 50Hz - High pressure	Parts 9,34,48,71,74,81,82,83,84,86,87,88.
W743606	Wear part set RL4157 - 60Hz - High pressure	Parts 9,34,48,71,74,81,82,83,84,86,87,88.

Note : Refer to spare part pages .

WIRING DIAGRAM

CONNECTION ↻ 3 PHASES

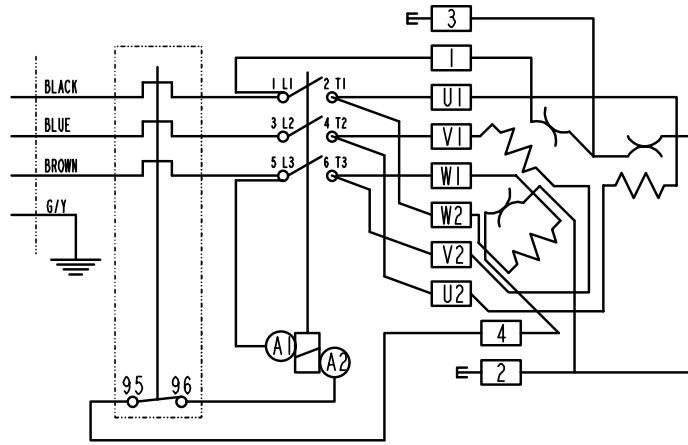

Option: overcurrent relay

CONNECTION ⊗ 3 PHASES

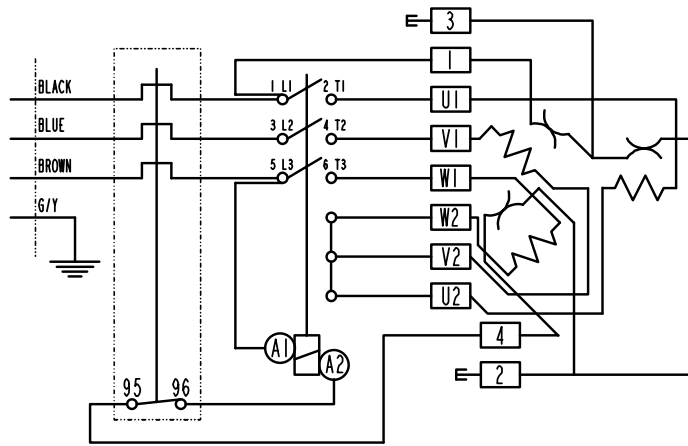

Option: overcurrent relay

DUAL VOLTAGE ⊗ ↻ 3 PHASES

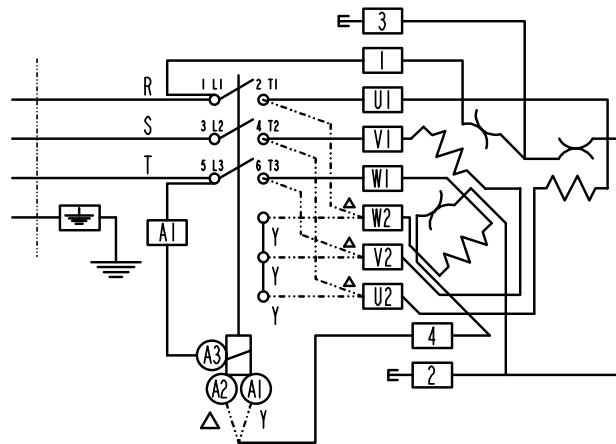

Option: overcurrent relay

ACCESSORIES

- ZINC ANODES P/N W254206

When pumping salt water (which is highly aggressive towards aluminium) , the pump should be protected with zinc anodes.

INSTALLATION

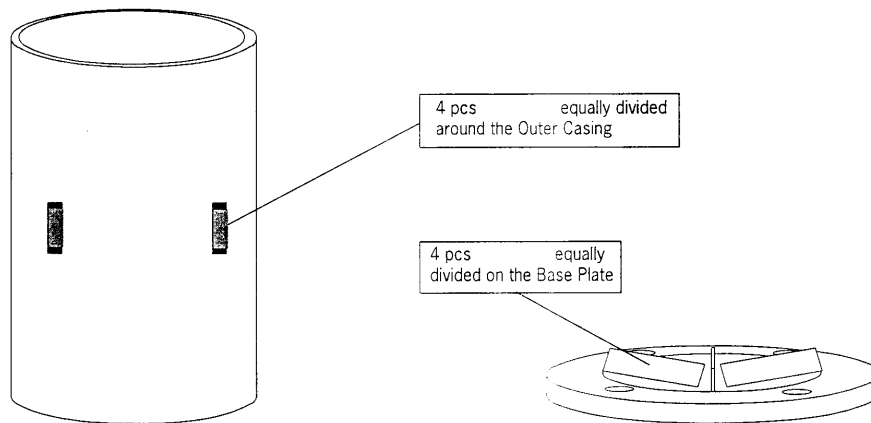

EXTRA EQUIPMENT

- LEVEL SENSOR NVB ITEM 121 (see sheet 13/14)

The RL4150 Serie pumps can be equipped with a built-in electronic level sensor , NVB . The pump starts automatically as the rising water reaches the electrodes on the contactor cover . The pump stops again , automatically , once the water level falls to the point at which the pump begin to suck in air through the strainer . The level sensor can be disconnected by bridging between the electrodes .

A pump equipped with NVB will not start if the wrong phase sequence is connected, or in case of phase failure.

If the pump does not stop when the water comes to at the strainer level, open the pump cover and adjust the NVB potentiometer to the "-" direction to get the stop.

If the pump stop before the water comes to the strainer level, adjust to the "+" direction.

REBUILDING SET NVB

400V 50Hz	W367209
500V 50Hz	W367210
440V 60Hz	W367211
220V 50Hz	W367212
240V 60Hz	W367213

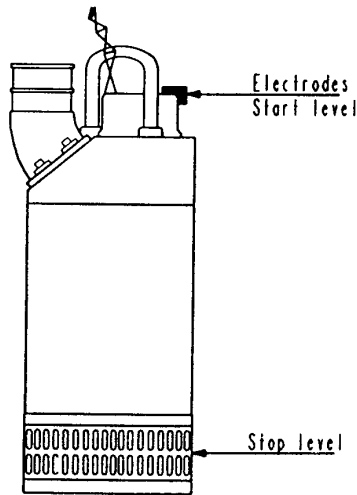

1. Electronic control box in contactor room
2. Pump cable to mains supply
3. Electrodes on outside of contactor cover
4. Short circuit jumper for electrodes
5. Pump's built-in contactor
6. Pump's electric motor
7. Bimetal breakers in the stator windings

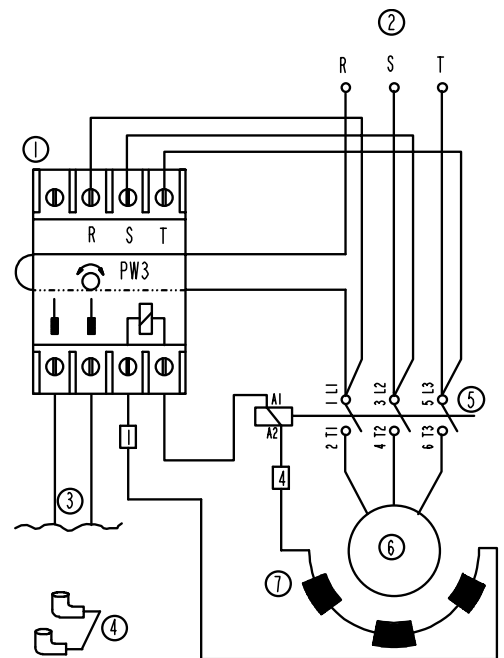

Built-in level control NVB

A pump with the NVB level control has an electronic control box (1) which feeds low-voltage current to two electrodes (3) in the contactor cover. On delivery, a short-circuit jumper (4) is connected between the electrodes. This enables the pump to be used for continuous operation. In order for the level control to work, the short-circuit jumper must be removed, which is done in a matter of seconds.

Function of the level control

The pump starts automatically when the rising water reaches the electrodes. It stops again as soon as air starts to be sucked in through the strainer.

The pump will not start if the phase sequence from the mains supply is incorrect and can therefore never be run backwards! If the phase sequence is incorrect, shift any two phases in the male plug.

Note that the current is always, cut off in the event of a phase failure and the pump also stops if , for example, the impeller is broken or the strainer is clogged.

Changing the start level

The start level can be raised (or lowered) by means of extension cords to the electrodes.

Thermal motor protection

The bimetals (7) interrupt the current to the contactor (5) if the motor overheats.

Changing the stop level

If the pump does not stop when the water has been pumped away, open the contactor cover and turn the potentiometer of the control box clockwise until the pump is turned off. If the pump stops too early, turn the potentiometer anticlockwise.

See the arrow on the electronic control box (1).

ADJUSTMENTS

You have 2 different potentiometers for adjustment.

- 1) Res A on the top of the NVB box
- 2) Res B in the box on the electronic board

THE PUMP DOESN'T STOP WHEN THE WATER LEVEL SINKS BELOW THE STRAINER.

- A) Turn "Res A" clockwise! OK?
- B) "Res A" back to mid position !
Put the R-phase cable even through the second hole in the NVB-box ! OK ?
- C) Turn "Res A" clockwise! OK?
- D) "Res A" back to mid position
Turn "Res B" counter clockwise (on the electronic board - open up the NVB-box -adjust and close the box again) OK ?
- E) Turn "Res B" according to D) above until the pump stops. Then fine adjust with "Res A".

THE PUMP STOPS BEFORE THE WATER LEVEL SINKS BELOW THE STRAINER.

- A) Just 1 cable through one of the holes in the NVB-box !
- B) Turn "Res A" counter clockwise ! OK ?
- C) "Res A" back to mid position !Turn "Res B" clockwise (on the electronic board - open up the NVB-box adjust and close the box again) OK ?
- D) Turn "Res B" according to B) above until the pump stops when the water level sinks down to the strainer. Fine adjust with "Res A".

WEDA PUMP

World leader in professional submersible drainage pumps

Delta Pompen B.V.

Rigaweg 17
9723 TE Groningen
The Netherlands
Tel.: +31 (0)50-2072380

E-mail: info@wedapump.com
Internet: <http://www.wedapump.com>

SERVICE AND GUARANTEE.

WEDAPUMP.COM is represented worldwide by a well-established service organization. Contact your local WEDAPUMP sales office if you require more information about servicing. Or left mentioned address.